

# VRN Dynamic Pressure-Regulating Control Valves and Actuators

## SPECIFICATION DATA



## APPLICATION

The VRN2 two-way dynamic pressure-regulating control valves maintain constant flow of hot or chilled water with glycol solutions up to 50% in closed-loop heating, ventilating, and air conditioning (HVAC Division 23) systems regardless of head pressure fluctuations above the minimum specified pressure drop. These valve assemblies can be used with Honeywell non-spring return or spring return direct coupled actuators (DCA) with minimum torque of 35 lb-in (4 Nm) on valve sizes up to 3 inches (DN80).

The built-in differential pressure regulator makes fluid flow through the valve independent of changes in supply pressure, eliminating "hunting" by the control system, even at low coil flow. The pressure regulator virtually eliminates cavitation in the valve, and decouples the control valve from the effects of piping components such as reducers and elbows.

Pressure independent control valves are sized to match design coil flow regardless of coil size. VRN2 valves eliminate the need to balance the system for proper flow, and allow chillers to be operated at design temperature differential for maximum efficiency at every load condition. When used in a system with variable speed pump drives, 3-way valves and coil bypass lines are not required. In new construction, VRN2 valves perform better than reverse return piping designs without the extra materials these systems need.

Pressure-independent control requires less flow, enabling use of smaller piping, pumps, and chillers.

## FEATURES

- Sizes from 1/2 to 3 in. with internal (female) NPT connections.
- Controls hot or chilled water with up to 50% glycol.
- Regulated flow rates available from 1 to 95 gpm.
- Differential pressure regulator for constant pressure drop across valve seat.
- Positive pressure, rolling diaphragm regulator design for flow control accuracy of  $\pm 5\%$ .
- Equal percentage flow characteristic using patented flow control ball insert.
- Multiple maximum flow rates available per valve size.
- Patented ball seals for low operating torque.
- Nickel-chrome plated brass or stainless steel trim.
- Choice of factory-installed actuation using Honeywell N05/S05-series direct coupled actuators: Floating, Modulating (2-10 V), Spring Return Modulating/ Floating.
- Spring return actuators field-configurable for normally open or normally closed fail-safe position.
- Removable, manual operating handle to control valve during installation or in an event of power failure.
- Upstream Test Port for venting or pressure gauge attachment.
- Three actuator orientations on the valve for cramped spaces.
- Integral snubber eliminates affect of system pressure fluctuations and entrapped air while improving flow performance.



# SPECIFICATIONS

**Valve Type:** Dynamic Pressure Regulated Control Valve

**Body Style:** Two-way ball valve, straight-through flow, full port with patented flow control insert.

**Pipe Size:** 1/2 to 3 inches with female NPT pipe fittings.

**Body Pressure Rating (maximum):** 360 psi (2500 kPa) at 250°F (121 C).

**Controlled Medium:** Water or Glycol solutions up to 50%. Not suitable for combustible gases, oil or steam.

**Medium Temperature Range:** -22 to +250°F (-30 to +121 C).

**Maximum Differential Pressure:** See Table 1.

**Close-off pressure:** 100 psid

**Flow Characteristics**

Equal Percentage with flow control insert. See Fig. 8.

**Materials**

**Body:** Forged Brass (ASTM B283).

**Flow Optimizer:** laser-milled, glass-reinforced Noryl®

**Trim (ball and stem):** Nickel-chrome plated brass, or stainless steel.

**Stem Seals:** EPDM O-ring and Teflon™ bearings.

**Ball Seals:** Reinforced Teflon™ seals, with EPDM O-rings.

**Regulator:** Hydrogenated acrylonitrile-butadiene rubber rolling diaphragm in stainless steel housing.

**Compatible Actuators**

**Minimum Torque Required:** 35 lb-in. (4 Nm) up to 3 in. (≤DN80).

18 lb-in. (2 Nm) up to 3/4 in. (and 1 in. up to 9 gpm).

**Non- spring return:** ML6161, ML7161, MN6105\*, MN7505\*.

**Spring return:** MS6105, MS7505\*, MS8105; MS6103, MS7503, MS8103 only at 1/2 in. or 3/4 in. (DN15 ~ DN 20).

\* These actuators available factory-installed.

See Table 3.

**Approvals Standards**

**Actuators:** See literature for the given actuator.

**Table 1. VRN Model Selection.**

| Model Selection: Ball Valve                   |                        |                |                                   |              |  |         |             | Actuator                                     | Fail Position      | Accessories            |   |    |
|---|------------------------|----------------|-----------------------------------|--------------|--|---------|-------------|--|--------------------|------------------------|---|----|
| Valve   | Fitting                | Body/Flow Type | Size                              | Max low rate | Trim                                   | Profile |             |  |                    |                        |   |    |
| VR - Dynamic pressure regulated control valve |                        |                |                                   |              |  |         |             | MVN613A0000                                  | FIP- Fail in place | C1- 1 meter            |   |    |
|   | N- Female NPT threaded |                |                                   |              |  |         |             | MVN613L0000                                  |                    |                        |   |    |
|   | 2- 2 way               |                |                                   |              |  |         |             | MVN643A0000                                  |                    |                        |   |    |
|   |                        |                |                                   |              |  |         |             | MVN643L0000                                  |                    |                        |   |    |
|   |                        |                |                                   |              |  |         |             | MVN713A0000                                  |                    |                        |   |    |
|   |                        |                |                                   |              |  |         |             | MVN713L0000                                  |                    |                        |   |    |
|   |                        |                | A---1/2 (DN15)                    |              |  |         | MN7505A2001 | FSO = Fail Safe Open                         | 3R                 |                        |   |    |
|   |                        |                | B--- 3/4 (DN20)                   |              |  |         | MS7505A2030 |  |                    | FSC = Fail Safe Closed |   |    |
|   |                        |                | C--- 1 (DN25)                     |              |  |         | MS8105A1030 | FSA = Fail A-AB Open<br>FSB = Fail B-AB Open |                    |                        |   |    |
|   |                        |                | D--- 1-1/4 (DN32)                 |              |  |         |             |  |                    |                        |   |    |
|   |                        |                | E--- 1-1/2 (DN40)                 |              |  |         |             |  |                    |                        |   |    |
|   |                        |                | F--- 2 (DN50)                     |              |  |         |             |  |                    |                        |   |    |
|   |                        |                | G--- 2-1/2 (DN65)                 |              |  |         |             |  |                    |                        |   |    |
|   |                        |                | H--- 3 (DN80)                     |              |  |         |             |  |                    |                        |   |    |
|   |                        |                | xxx.xx - Max flow rate designator |              |  |         |             |  |                    |                        |   |    |
|   |                        |                |                                   |              | P- Plated Brass<br>S - Stainless Steel |         |             |  |                    |                        |   |    |
|   |                        |                |                                   |              | A - Standard Base                      |         |             |  |                    |                        |   |    |
| VR  | N                      | 2              | A                                 | 001.00       | P                                      | A       | +           | MVN613A0000                                  | +                  | FIP                    | + | C1 |

Example part number: VRN2A001.00PA+MVN613A0000+FIP+C1

**Table 2. Actuator Control Description.**

| <b>Actuator</b> | <b>Control</b>                      |
|-----------------|-------------------------------------|
| MVN613A0000     | Floating (90 sec. timing)           |
| MVN613L0000     |                                     |
| MVN643A0000     | Fast Acting SPDT (30 sec. timing)   |
| MVN643L0000     |                                     |
| MVN713A0000     | Modulating                          |
| MVN713L0000     |                                     |
| MN6105A1011     | Floating, Modulating, On/Off (SPDT) |
| MN7505A2001     |                                     |
| MS7505A2030     |                                     |
| MS8105A1030     | Two-Position (SPST)                 |

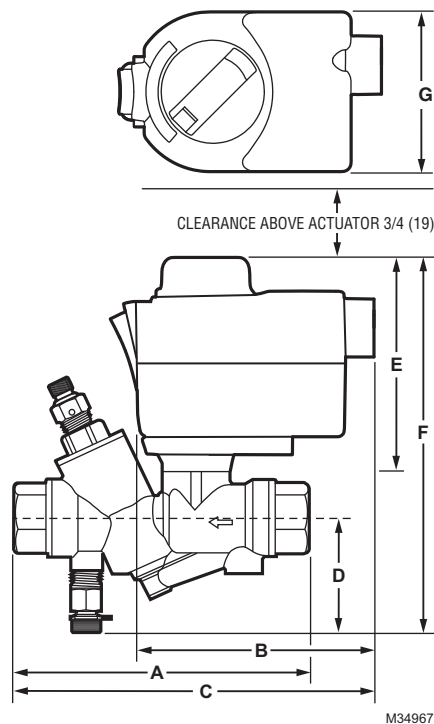

Fig. 1. Dimensions; see Table 3.

Table 3. Valve Dimensions.

| Model | Pipe Size |      | Flow, gpm (m <sup>3</sup> /h) |             |             | Dimensions in in. (mm) |            |            |           |            |           |  | Weight lb. (kg) | Service Replacement Parts  |
|-------|-----------|------|-------------------------------|-------------|-------------|------------------------|------------|------------|-----------|------------|-----------|--|-----------------|--|
|       | NPT       | in.  | S.I. metric                   | Min. Rating | Max. Rating | Full Port              | A          | B          | C         | D          | E         | F  |                 |  |
| VRN2A | 1/2       | DN15 | 1.0 (0.23)                    | 7.0 (1.6)   | 10 (2.3)    | 5.7 (145)              | 4.56 (116) | 6.6 (167)  | 1.03 (26) | 3.87 (98)  | 8.4 (212) | 2.19 (71)  | 0.9 (0.4)       | Stem: 5112-34<br>5112-37 (SS);<br>Regulator:<br>8615-100 for 1 to 3 gpm;<br>8615-101 for 4 to 10 gpm |
| VRN2B | 3/4       | DN20 |                               | 9.0 (2.0)   |             | 6.6 (167)              |            |            |           |            |           |  |                 |  |
| VRN2C | 1         | DN25 | 10 (2.3)                      | 20 (4.5)    | 35 (7.9)    | 5.9 (150)              | 9.0        | 6.7 (170)  | 1.6 (41)  | 9.4 (237)  | 1.5 (0.7) |  |                 |  |
|       |           |      |                               |             |             | 9.0                    |            | 8.6        |           |            |           |  |                 |  |
| VRN2D | 1 1/4     | DN32 | 35 (7.9)                      | 50 (11.4)   | 95 (21.6)   | 8.4                    | 10.0       | 8.5        | 2.1 (53)  | 10.4 (262) | 3.6 (1.6) | Stem: 5112-35<br>5112-38 (SS);<br>Regulator:<br>8615-102 |                 |  |
| VRN2E | 1 1/2     | DN40 |                               |             |             | 8.2                    |            | 8.5        |           |            |           |  |                 |  |
| VRN2F | 2         | DN50 | 25 (5.7)                      | 75 (17.0)   | 95 (21.6)   | 10.0                   | 10.1       | 10.0 (253) | 2.1 (53)  | 10.4 (262) | 3.6 (1.6) | Stem: 5112-36<br>5112-39 (SS);<br>Regulator:<br>8615-031 |                 |  |
|       |           |      |                               |             |             | 9.9 (251)              |            | 10.0 (253) |           |            |           |  |                 |  |
| VRN2G | 2 1/2     | DN65 | 25 (5.7)                      | 75 (17.0)   | 95 (21.6)   | 10.8 (274)             | 10.8 (274) | 10.8 (274) | 2.1 (53)  | 10.4 (262) | 3.6 (1.6) | Stem: 5112-36<br>5112-39 (SS);<br>Regulator:<br>8615-031 |                 |  |
| VRN2H | 3         | DN80 |                               |             |             | 11.2 (284)             |            | 11.2 (284) |           |            |           |  |                 |  |

## MVN Actuator



## APPLICATION

MVN 3Nm (27 lb-in.) Control Valve Actuator is used with the VRN2 Dynamic pressure regulated control valves to control hot and chilled water with glycol solutions up to 50% in heating, ventilating, and air conditioning (HVAC) systems to provide two-position or modulating functions.

## FEATURES

- **Non-spring Return**
- **Floating and modulating**
- **Space saving, click-on installation – no tool required**
- **Extendable position indicator for easy commissioning**
- **Available with or without cable**
- **Compatible with control ball valves from 1/2 to 1-1/4 inches.**
- **Actuator can be mounted on the valve in any of four positions.**

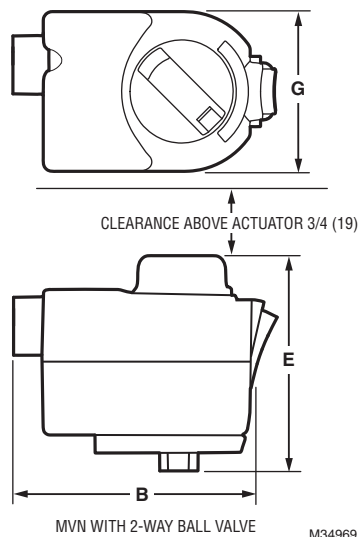

Fig. 2. Dmensions; see Table 3 on page 4.

## SPECIFICATIONS

**Actuator Type:** Valve

**Rotational Stroke:** 90° ±3°.

**Fail Safe Mode:** Non-spring return

**Torque:** 27 lb-in. (3 Nm).

**External Auxiliary Switches Available:** No

**Environmental Rating:** NEMA2

**Frequency:** 50 Hz; 60 Hz

**Mounting:** Click-on installation – no tool required

**Noise Rating at 1m (Maximum):** 35 dB(A) max at 1 m [50 dB (A) for MVN643].

**Materials:** Plenum rated plastic housing

**Operating Humidity Range (% RH):** 5 to 95% RH, non-condensing

**Ambient Temperature Range:** -4°F to 131°F (-20°C to 55°C)

**Storage Temperature Range:** -40°F to 176°F (-40°C to 80°C)

**Weight:**

**Dimensions:** See Fig. 4-6

**Timing:** 90 sec. for MVN613 and MVN713; 30 sec. for MVN643

**Electrical Connections:** Field wiring 18 to 20 AWG to screw terminals, located under the removable access cover.

**Humidity Ratings:** 5% to 95% RH noncondensing.

**Design Life (at Rated Voltage):** 60,000 cycles; 1 cycle = 0°...90°...0°

**Cable Specification:**

18 AWG, Plenum Rated, 300 V, 10 A, 3 ft. length from end of access cover.

**Environmental Protection Ratings:** IP40.

**Approvals:**

UL/cUL  
UL60730

Table 4. Actuators and Accessories

| Actuator    | Description                                  | Accessory         |
|-------------|--|-------------------|
| MVN613A0000 | Floating control ball valve actuator         | C1- 1 meter cable |
| MVN613L0000 | Floating control ball valve actuator         |                   |
| MVN643A0000 | Fast acting SPDT control ball valve actuator |                   |
| MVN643L0000 | Fast acting SPDT control ball valve actuator |                   |
| MVN713A0000 | Modulating control ball valve actuator       |                   |
| MVN713L0000 | Modulating control ball valve actuator       |                   |

To order actuator with accessories order actuator part number + accessory. For example: MVN613A0000 + C1

## Non-Spring Return Direct Coupled Actuator

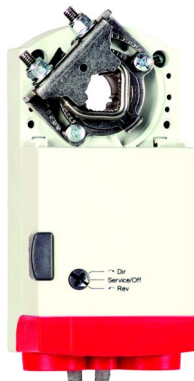

## APPLICATION

This non-spring return direct-coupled damper actuator provides modulating and floating/2-position control for: air dampers, air handlers, ventilation flaps, louvers, and reliable control for air damper applications with up to 10 sq. ft./ 44lb.-in. (5 Nm) and 20 sq. ft./88 lb.-in. (10 Nm) (seal-less damper blades; air friction-dependent).

## FEATURES:

- **Declutch for manual adjustment**
- **Adjustable mechanical end limits**
- **Access cover includes enclosed screw terminal strip (22 to 14 AWG) for electrical connections**
- **Models available with 3 foot 18 AWG color-coded cable**
- **Mountable in any orientation**
- **Function selection switch for selecting modulating or floating/2-position control**

## SPECIFICATIONS

**Actuator Type:** Damper; Valve

**Rotational Stroke:** 95° ±3 degrees

**Fail Safe Mode:** Non-spring return

**Torque:** 44 lb.-in. (5 Nm)

**External Auxiliary Switches Available:** Yes, SSW2-1M

**Environmental Rating:** NEMA2

**Frequency:** 50 Hz; 60 Hz

**Manual operation:** Declutch mechanism

**Mounting:** Direct coupled

**Maximum Noise Rating, Driving (dBA @ 1m):** 35

**Rotation to Open:** By switch

**Rotational Stroke Adjustment:** Dual Integral Adj. Stops (3 degree increments)

**Compatible Damper Shafts:** 1/4 to 1/2 in. square or 3/8 to 5/8 in. round (6 to 13 mm square or 8 to 16 mm round)

**Shaft Adapter Type:** U-bolt clamp

**Supply Voltage:** 24 Vac +20%, -15%, 24 Vdc

**Materials:** Plenum rated plastic housing

**Ingress Protection Rating:** IP54

**Operating Humidity Range (% RH):** 5 to 95% RH, non-condensing

**Ambient Temperature Range:** -5°F to +140°F (-20°C to +60° C)

**Storage Temperature Range:** -22°F to +176°F (-30°C to +80°C)

**Weight:** 1 lb (0.45 kg)

**Includes:** Mounting bracket, screws, shaft adapter, water-tight strain-relief cable fittings

**Comments:** Integral 1/2 in. NPSM conduit connection.

### Approvals:

CE: 89/336/ECC, 73/23/EEC

C-Tick: N314

Underwriters Laboratories, Inc.: UL873, Plenum Rated

Canadian Underwriters Laboratories, Inc.: cUL C22.2 No. 24-93

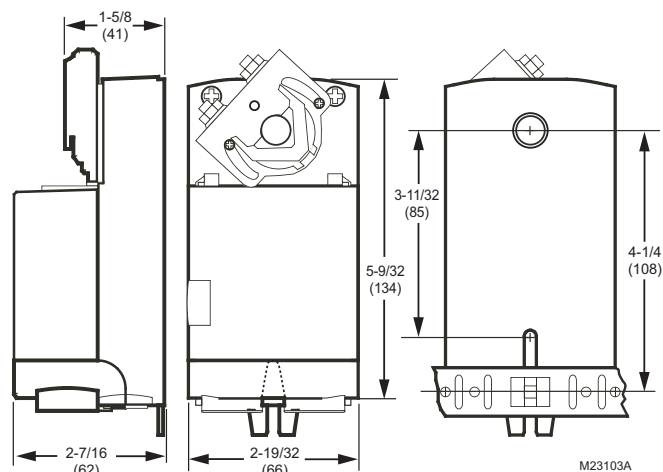

**Fig. 3. Non-spring return direct coupled actuator dimensions diagram.**

## Spring Return Direct Coupled Actuator



## APPLICATION

MS4105, MS7405, MS7505, and MS8105 Spring Return Direct Coupled Actuators (DCA) are used within heating, ventilating, and air-conditioning (HVAC) systems. They can drive a variety of quarter-turn, final control elements requiring spring return fail-safe operation.

## FEATURES

- **Brushless DC submotor with electronic stall protection on all models**
- **Self-centering shaft adaptor (shaft coupling) for wide range of shaft sizes**
- **Access cover includes enclosed screw terminal strip (22 to 14 AWG) for electrical connections.**
- **Models available with 3 foot 18 AWG color-coded cable**
- **Durable plastic housing with built-in mechanical end limits**
- **Spring return direction field selectable**
- **Shaft position indicator and scale**
- **UL (cUL) listed and CE compliant**
- **All models are plenum rated per UL873**

## SPECIFICATIONS

**Actuator Type:** Damper; Valve

**Rotational Stroke:** 95 ±3 degrees

**Fail Safe Mode:** Spring Return

**Torque:** 44 lb-in. (5 Nm)

**Spring Return Torque:** 44 lb-in. (5 Nm)

**Spring Return Direction:** By orientation

**External Auxiliary Switches Available:** No

**Environmental Rating:** NEMA2

**Frequency:** 50 Hz; 60 Hz

**Mounting:** Direct Coupled

**Maximum Noise Rating, Holding (dBA @ 1m):** 20 (no audible noise)

**Maximum Noise Rating, Driving (dBA @ 1m):** 50

**Rotation to Open:** By switch

**Rotational Stroke Adjustment:** Mechanically limited 5 degree increments

**Compatible Damper Shafts:** 1/4 to 1/2 in. square or 3/8 to 5/8 in. round (6 to 13 mm square or 9 to 16 mm round)

**Shaft Adapter Type:** Self-centering clamping

**Materials:** Plenum rated plastic housing

**Supply Voltage:** 24 Vac +20%, -15%, 24 Vdc

**Operating Humidity Range (% RH):** 5 to 95% RH, non-condensing

**Ambient Temperature Range:** -40°F to +149°F (-40°C to +65°C) for two-position actuators only

**Storage Temperature Range:** -40°F to +150°F (-40°C to +65°C)

**Weight:** 3.5 lb. (1.6 kg)

**Includes:** Mounting bracket, self-centering shaft adapter

### Approvals:

CE: EMC 2004/108/EC; Certification Low Voltage Directive 2006/95/EC; IEC 60730-1 and Part 2-14

C-Tick: N314

Underwriters Laboratories, Inc.: UL873

Canadian Underwriters Laboratories, Inc.: cUL C22.2 No. 24-93

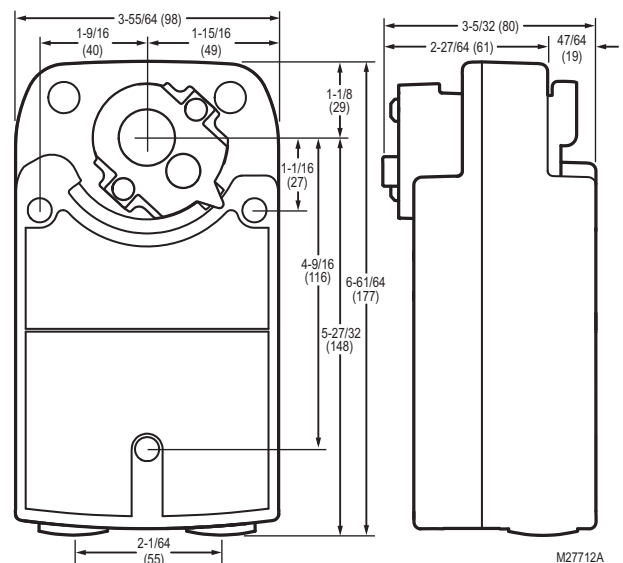

**Fig. 4. Spring return direct coupled actuator dimensions diagram.**

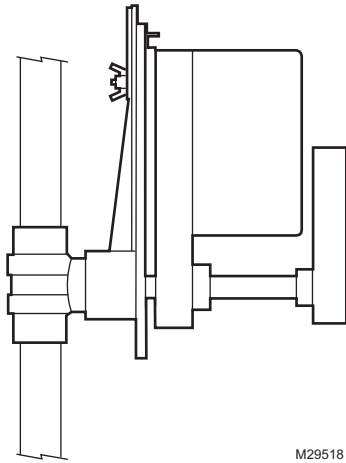

Fig. 5. Vertical valve installation.

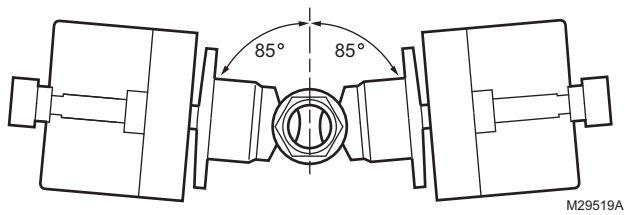
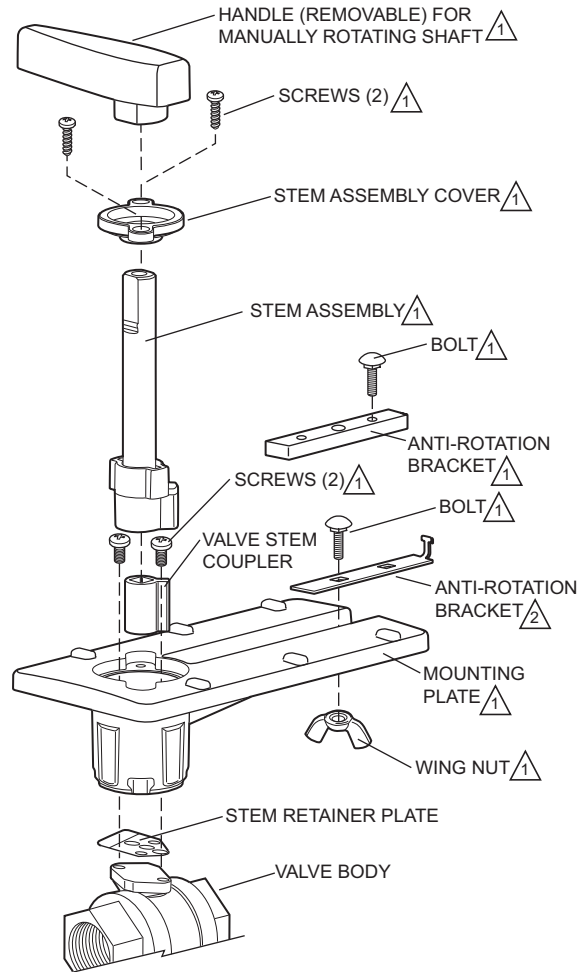

Fig. 6. Acceptable valve angle from vertical.



1 INCLUDED IN REPLACEMENT KIT (PART NO. 5112-11).

2 THIS PART USED WITH NON-SPRING RETURN ACTUATORS. M29526

Fig. 7. Actuator mounting plate adjustment.

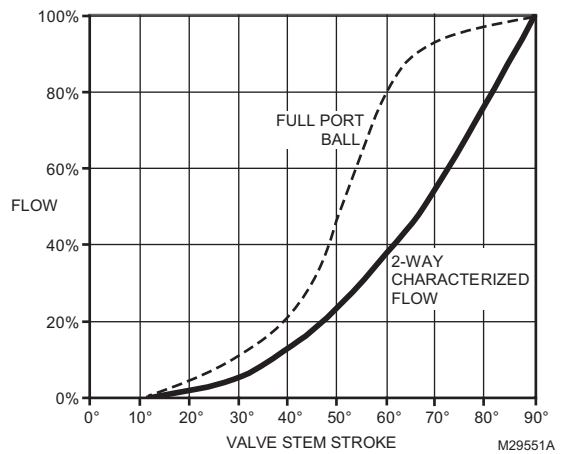

Fig. 8. Typical flow characteristics.



**Table 5. Flow rate and deferential pressure**

|       |                               |        |        |        |        |        |        |        |        |        |        |        |         |
|-------|-------------------------------|--------|--------|--------|--------|--------|--------|--------|--------|--------|--------|--------|---------|
| VRN2A | Max flow rate                 | 1.00   | 2.00   | 3.00   | 4.00   | 5.00   | 6.00   | 7.00   |        |        |        |        |         |
|       | min/max differential pressure | 3.0/35 | 3.0/35 | 3.0/35 | 3.0/35 | 3.0/35 | 3.0/35 | 3.0/35 |        |        |        |        |         |
| VRN2B | Max flow rate                 | 1.00   | 2.00   | 3.00   | 4.00   | 5.00   | 6.00   | 7.00   | 8      | 9      | 10     |        |         |
|       | min/max differential pressure | 3.0/35 | 3.0/35 | 3.0/35 | 3.0/35 | 3.0/35 | 3.0/35 | 3.0/35 | 6.0/35 | 6.0/35 | 6.0/35 |        |         |
| VRN2C | Max flow rate                 | 1.00   | 2.00   | 3.00   | 4.00   | 5.00   | 6.00   | 7.00   | 8      | 9      | 10     | 15     | 20      |
|       | min/max differential pressure | 3.0/35 | 3.0/35 | 3.0/35 | 3.0/35 | 3.0/35 | 3.0/35 | 3.0/35 | 6.0/35 | 6.0/35 | 3.0/50 | 3.0/50 | 4.0/50  |
| VRN2D | Max flow rate                 | 10     | 15     | 20     | 25     | 30     | 35     |        |        |        |        |        |         |
|       | min/max differential pressure | 3.0/50 | 3.0/50 | 4.0/50 | 5.0/50 | 5.0/50 | 6.5/58 |        |        |        |        |        |         |
| VRN2E | Max flow rate                 | 10     | 15     | 20     | 25     | 30     | 35     | 40     | 45     | 50     |        |        |         |
|       | min/max differential pressure | 3.0/50 | 3.0/50 | 4.0/50 | 5.0/50 | 5.0/50 | 4.0/58 | 6.0/58 | 6.0/58 | 6.0/58 |        |        |         |
| VRN2F | Max flow rate                 | 25     | 30     | 35     | 40     | 45     | 50     | 55     | 60     | 65     | 70     | 75     | 80      |
| VRN2G | min/max differential pressure | 4.0/58 | 4.0/58 | 4.0/58 | 6.0/58 | 6.0/58 | 6.0/58 | 7.0/58 | 7.0/58 | 7.0/58 | 7.0/58 | 7.0/58 | 10.0/58 |
| VRN2H |                               |        |        |        |        |        |        |        |        |        |        |        |         |

**Application Notes**

**IMPORTANT**

*Valve sizing is important for correct system operation. Undersized valves do not have sufficient capacity at maximum load. Oversized valves do not have sufficient authority over the load in modulating applications.*

*Oversized valves can cause excessive cycling and the seat and ball can be damaged because of the restricted opening.*

**Proper Use**

These valves are only for use in cold, warm, and hot water systems. Not suitable for oil, combustible gases, or steam. They are designed for a medium temperature range of from 35 to 250°F, at a maximum pressure of 360 psig VRN valves are to be operated with the appropriate Honeywell direct coupled actuators only.

Water should be properly filtered, treated and conditioned according to local conditions and the recommendations of the boiler or chiller manufacturers. The installation of a strainers and filters is recommended.

**IMPORTANT**

*The presence of excessive iron oxide (red rust) in the system voids the valve warranty.*

**Required Operating Torque**

Both Honeywell non-spring return MVN and spring return low torque direct coupled actuators can be utilized with the VRN2 valves. VR valves use a patented seat design that reduces the torque needed from the actuator.

**Table 6. Close-off, Differential Pressure Ratings.**

| Valve Type | Valve Size                  | Close-off Pressure Rating (psi) |
|------------|-----------------------------|---------------------------------|
| 2 way      | 1/2 in., 3/4 in.            | 100                             |
|            | 1 in., 1-1/4 in., 1-1/2 in. | 100                             |

**TYPICAL SPECIFICATIONS**

**Valve Actuator**

Direct coupled actuator shall accept analog modulating [(0)2-10 Vdc], floating (tri-state), or two-position signal as indicated in the control sequence. Actuators shall be by Honeywell. Actuator shall provide minimum torque required for full valve shutoff position. Wiring terminals shall be provided for installation to control signal and power wiring.

Actuator shall be available with housing suitable for outdoor installation.

Accessories Identification tags shall be available for all valves.

**Table 7. Actuator Accessories and Replacement Parts.**

| Part Number  | Description  | MV/N613A0000 | MV/N643A0000 | MV/N713A0000 | MN6105A1011 | MN7505A2001 | MS7505A2030 | MS8105A1030 |
|--------------|--|--------------|--------------|--------------|-------------|-------------|-------------|-------------|
| 5112-3R      | Weather Enclosure Assembly                                       |              |              |              | x           | x           | x           | x           |
| MVNAAA       | Replacement Valve Adaptor  | x            | x            | x            |             |             |             |             |
| MVNAAL       | Replacement Valve Adaptor, Low Profile                           |              |              |              |             |             |             |             |
| MVNAC7131    | Replacement Cable with Terminal 1m, Modulation (RED,BLACK,WHITE) |              |              | x            |             |             |             |             |
| MVNAC6131    | Replacement Cable with Terminal 1m, Floating(RED,BLACK,WHITE)    | x            | x            |              |             |             |             |             |
| MVNAT3       | Replacement Screw type Terminal Block, Pluggable                 | x            | x            | x            |             |             |             |             |
| 5112-11      | Replacement actuator bracket                                     |              |              |              | x           | x           | x           | x           |
| 205860       | Minimum position Potentiometer                                   |              |              |              | x           | x           | x           | x           |
| 32006306-001 | Resistor Kit (500 ohm); converts 4-20 mA signal to 2-10 Vdc      |              |              |              |             |             | x           | x           |
| Q7002B1009   | Universal Interface Modeule                                      |              |              |              | x           | x           | x           | x           |
| STRN-SCSA    | Self-centering Shaft Adapter                                     |              |              |              |             |             | x           | x           |
| 32000085-001 | Strain Relief Fitting (10 pack)                                  |              |              |              | x           | x           | x           | x           |
| AT120A1004   | 120 to 24 Vac Transformer (20 VA)                                | x            | x            | x            | x           | x           | x           | x           |
| AT140A1000   | 120 to 24 Vac Transformer (40 VA)                                | x            | x            | x            | x           | x           | x           | x           |
| STRN-STRNRLF | Stain Relief Fitting (10 pack)                                   |              |              |              |             |             | x           | x           |



**Automation and Control Solutions**

Honeywell International Inc.  
1985 Douglas Drive North  
Golden Valley, MN 55422  
[customer.honeywell.com](http://customer.honeywell.com)

© U.S. Registered Trademark  
© 2013 Honeywell International Inc.  
62-3115EFS—01 M.S. 08-13  
Printed in United States

**Honeywell**